

SFP+ 16G 1310nm 10Km LR

GS-16G31-LR



Overview

GS-16G31-LR SFP+ transceivers, according to 16 Gigabit Small Form Factor Pluggable “SFP+” Multi-Sourcing Agreement (MSA) SFF-8431 Rev. 3.0 and SFF-8472 Rev. 11.0, are designed for use in Fibre Channel links up to 14.025Gb/s data rate and up to 10km link length. They are compatible with FC-PI-5 Rev. 6.10 and SFF-8432.

GS-16G31-LR offers the commercial operating temperature options.

Features

- ◆ Up to 14.025Gb/s bi-directional data links
- ◆ Electrical interface specifications per SFF-8431
- ◆ Management interface specifications per SFF-8432 and SFF-8472
- ◆ SFP+ MSA package with duplex LC connector
- ◆ Build-in Dual CDR at 14.025Gb/s and bypass at 4.25Gb/s and 8.5Gb/s
- ◆ Uncooled 1310nm DFB Laser
- ◆ Up to 10 km on 9/125um SMF
- ◆ Single +3.3V power supply
- ◆ Class 1 laser safety certified)
- ◆ 1.8W maximum power consumption with established link
- ◆ Operating case temperature: 0 to 70 °C
- ◆ RoHS Compliant

Applications

- ◆ Tri Rate 4.25 / 8.5 / 14.025 Gb/s Fibre Channel Rate

Ordering Information

Part Number	Product Description
GS-16G31-LR	SFP+ 16Gbps, 1310nm, 10km, 0°C ~ +70°C

Absolute maximum rating

Stresses in excess of the absolute maximum ratings can cause permanent damage to the device. These are absolute stress ratings only. Functional operation of the device is not implied at these or any other conditions in excess of those given in the operational sections of the data sheet. Exposure to absolute maximum ratings for extended periods can adversely affect device reliability.

Parameters	Symbol	Min.	Max.	Unit
Power Supply Voltage	V_{CC}	-0.5	+4.0	V
Storage Temperature	T_c	-40	+85	°C
Relative Humidity	RH	5	95	%

Recommended Operating Condition

Parameter	Symbol	Min.	Typical	Max	Unit
Power Supply Voltage	V_{CC}	3.135	3.300	3.465	V
Operating Case Temperature	T_c	0	25	70	°C
Data Rate	-	-	4.25/8.5/14.025		Gb/s

Transceiver Electrical Characteristics

Parameter	Symbol	Minimum	Typical	Maximum	Unit	Notes	
Module Supply Current	I_{CC}	-		550	mA	-	
Power Dissipation	P_D	-	-	1800	mW	-	
Transmitter							
Input Differential Impedance	Z_{IN}	-	100	-	Ω	-	
Differential Data Input Swing	$V_{IN, P-P}$	180	-	700	mV _{P-P}	-	
TX_FAULT	Transmitter Fault	V_{OH}	2.0	-	V_{CCHOST}	V	-
	Normal Operation	V_{OL}	0	-	0.8	V	-
TX_DISABLE	Transmitter Disable	V_{IH}	2.0	-	V_{CCHOST}	V	-
	Transmitter Enable	V_{IL}	0	-	0.8	V	-
Receiver							
Output Differential Impedance	Z_O	-	100	-	Ω	-	
Differential Data Output Swing	$V_{OUT, P-P}$	300	-	850	mV _{P-P}	1	
Data Output Rise Time, Fall Time	t_r, t_f	28	-	-	ps	2	
RX_LOS	Loss of signal (LOS)	V_{OH}	2.0	-	V_{CCHOST}	V	3
	Normal Operation	V_{OL}	0	-	0.8	V	3

Notes:

1. Internally AC coupled, but requires an external 100 Ω differential load termination.
2. 20 – 80 %.
3. LOS is an open collector output. Should be pulled up with 4.7k Ω on the host board.

Transmitter Optical Characteristics

Parameter	Symbol	Minimum	Typical	Maximum	Unit	Notes
Launch Optical Power, 14.025 Gb/s	P _{O,RH}	-5	-	2	dBm	1, 2
Launch Optical Power, 4.25 Gb/s, 8.5 Gb/s	P _{O,RL}	-5	-	-1	dBm	3
Center Wavelength Range	λ_c	1295	1310	1325	nm	4
Optical Modulation Amplitude @ 4.25, 8.5Gb/s	OMA	290	-	-	uW	4, 6
Optical Modulation Amplitude @ 14.025 Gb/s	OMA	631	-	-	uW	6
Transmitter and Dispersion Penalty @ 8.5 Gb/s	TDP	-	-	3.2	dB	7
Transmitter and Dispersion Penalty @ 14.025 Gb/s	TDP	-	-	4.4	dB	7
Spectral Width	$\Delta\lambda$	-	-	1	nm	4, 5
Optical Rise/Fall Time @ 4.25 Gb/s	t _r /t _f	-	-	90	ps	8
Optical Return Loss Tolerance	ORLT	-	-	12	dB	-
P _{out} @TX-Disable Asserted	P _{off}	-	-	-30	dBm	9

Notes:

- Class 1 Laser Safety per FDA/CDRH and EN (IEC) 60825 regulations.
- High Bandwidth Mode. Class 1 Laser Safety per FDA/CDRH and EN (IEC) 60825 regulations.
- Low Bandwidth Mode. Class 1 Laser Safety per FDA/CDRH and EN (IEC) 60825 regulations.
- Also specified to meet curves in FC-PI-5 Rev 6.10 Figures 23, 24, and 25, which allow trade-off between wavelength, spectral width and OMA for 4.25 and 8.5 Gb/s operation.
- 20dB spectral width.
- Equivalent extinction ratio specification for Fibre Channel. Allows smaller ER at higher average power.
- For 14.025 and 8.5 Gb/s operation, Jitter values for gamma T and gamma R are controlled by TDP.
- Unfiltered, 20-80%. Complies with IEEE 802.3 (Gig. E), FC 4x eye masks when filtered.
- The optical power is launched into 9/125 μ m SMF.

Receiver Optical Characteristics

Parameter	Symbol	Minimum	Typical	Maximum	Unit	Notes
Center Wavelength	λ_c	1260	1310	1370	nm	-
Unstress Receiver OMA Sensitivity = 4.25 Gb/s	RxSENS	-	-	-15.4	dBm	1
Unstress Receiver OMA Sensitivity = 8.5 Gb/s	RxSENS	-	-	-13.7	dBm	1
Unstress Receiver OMA Sensitivity = 14.025 Gb/s	RxSENS	-	-	-12.0	dBm	2
Receiver Overload (P _{avg})	P _{OL}	2	-	-	dBm	
Optical Return Loss	ORL	12	-	-	dB	-
LOS De-Assert	LOS _D	-	-	-16	dBm	-
LOS Assert	LOS _A	-30	-	-	dBm	-
LOS Hysteresis	-	0.5	-	-	dB	-

Notes:

- Measured with PRBS 2⁷-1 at 10⁻¹² BER.
- Measured with PRBS 2³¹-1 at 10⁻¹² BER.

General Specifications

Parameter	Symbol	Minimum	Typical	Maximum	Unit	Notes
Data Rate	BR	4.25	-	14.025	Gb/s	1
Bit Error Rate	BER			10^{-12}		2
Supported Link Length on 9/125um SMF, 4.25, 8.5, 14.025 Gb/s	LMAX1	-	10		km	3

Notes:

- 4x/8x/16x Fibre Channel compliant.
- Tested with a PRBS 2^7-1 test pattern for 4.25 and 8.5Gb/s operation. Tested with a PRBS $2^{31}-1$ test pattern for 14.025Gb/s operation.
- Distances are based on FC-PI-5 Rev. 6.10 and IEEE 802.3 standards.

Pin Definition

Pin	Symbol	Name/Description	Note
1	VEET	Transmitter Ground	1
2	TX_Fault	Transmitter Fault (LVTTTL-O) - High indicates a fault condition	2
3	TX_Disable	Transmitter Disable (LVTTTL-I) – High or open disables the transmitter	3
4	SDA	Two wire serial interface Data Line (LVCMOS-I/O) (MOD-DEF2)	4
5	SCL	Two wire serial interface Clock Line (LVCMOS-I/O) (MOD-DEF1)	4
6	MOD_ABS	Module Absent (Output), connected to VeeT or VeeR in the module	5
7	RS0	Rate Select 0 – Not used, Presents high input impedance	6
8	RX_LOS	Receiver Loss of Signal (LVTTTL-O)	2
9	RS1	Rate Select 1 – Not used, Presents high input impedance	6
10	VeeR	Receiver Ground	1
11	VeeR	Receiver Ground	1
12	RD-	Inverse Received Data out (CML-O)	-
13	RD+	Received Data out (CML-O)	-
14	VeeR	Receiver Ground	-
15	VccR	Receiver Power - +3.3V	-
16	VccT	Transmitter Power - +3.3 V	-
17	VEET	Transmitter Ground	1
18	TD+	Transmitter Data In (CML-I)	-
19	TD-	Inverse Transmitter Data In (CML-I)	-
20	VEET	Transmitter Ground	1

Notes:

- The module signal grounds are isolated from the module case.
- This is an open collector/drain output that on the host board requires a 4.7KΩ to 10KΩ pull-up resistor to VccHost.
- This input is internally biased high with a 4.7KΩ to 10KΩ pull-up resistor to VccT.
- Two-Wire Serial interface clock and data lines require an external pull-up resistor dependent on the capacitance load.

- 5. This is a ground return that on the host board requires a 4.7KΩ to 10KΩ pull-up resistor to VccHost.
 - 6. Rate select can also be set through the 2-wire bus in accordance with SFF-8472 v. 11.0, Rx Rate Select is set at Bit 3, Byte 110, Address A2h. Tx Rate Select is set at Bit 3, Byte 118, Address A2h.
- Note:** writing a "1" selects maximum bandwidth operation. Rate select is the logic OR of the input state of Rate Select Pin and 2-wire bus.

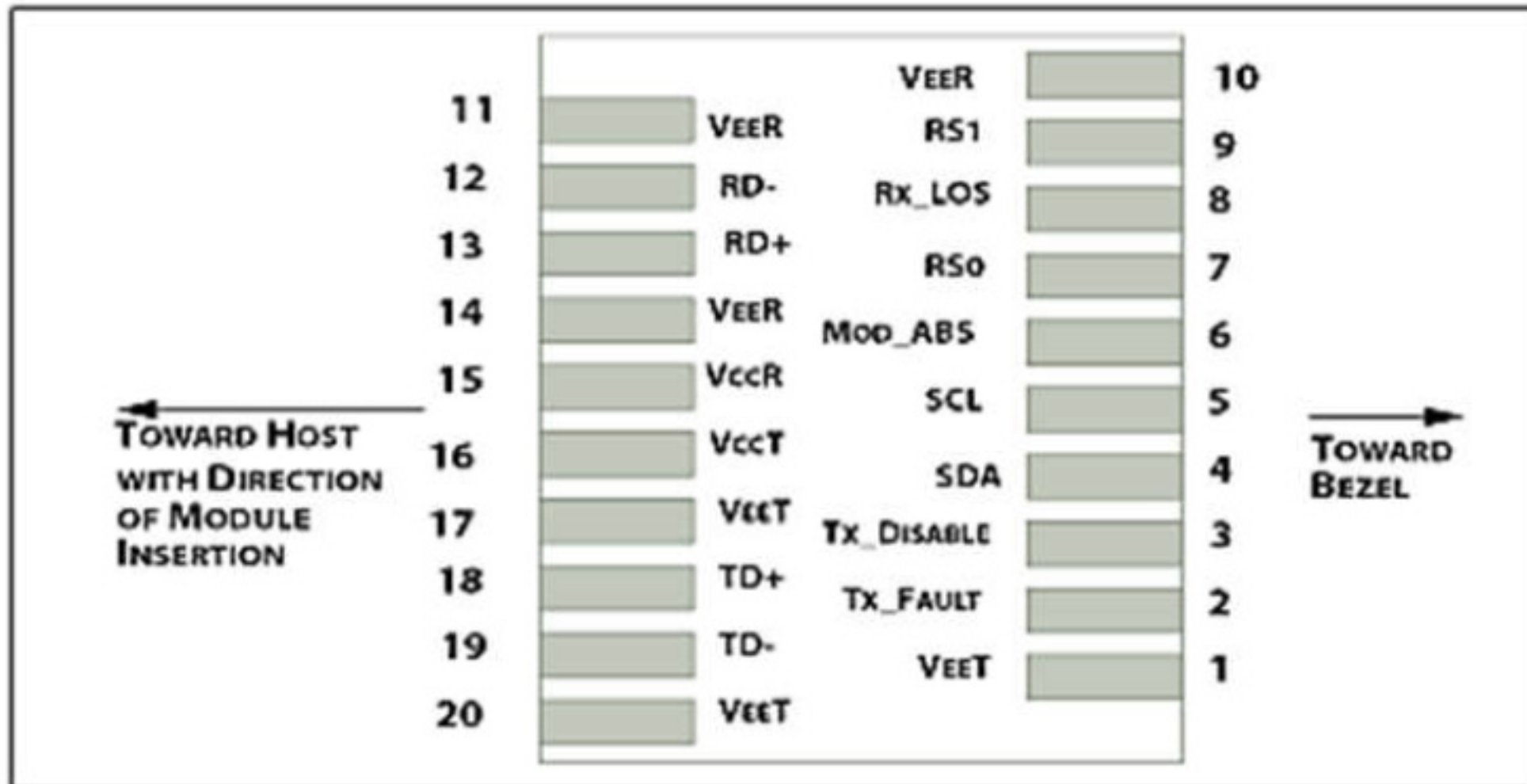

Figure 1: Interface to Host PCB

Recommended Host Board Power Supply Filter Network

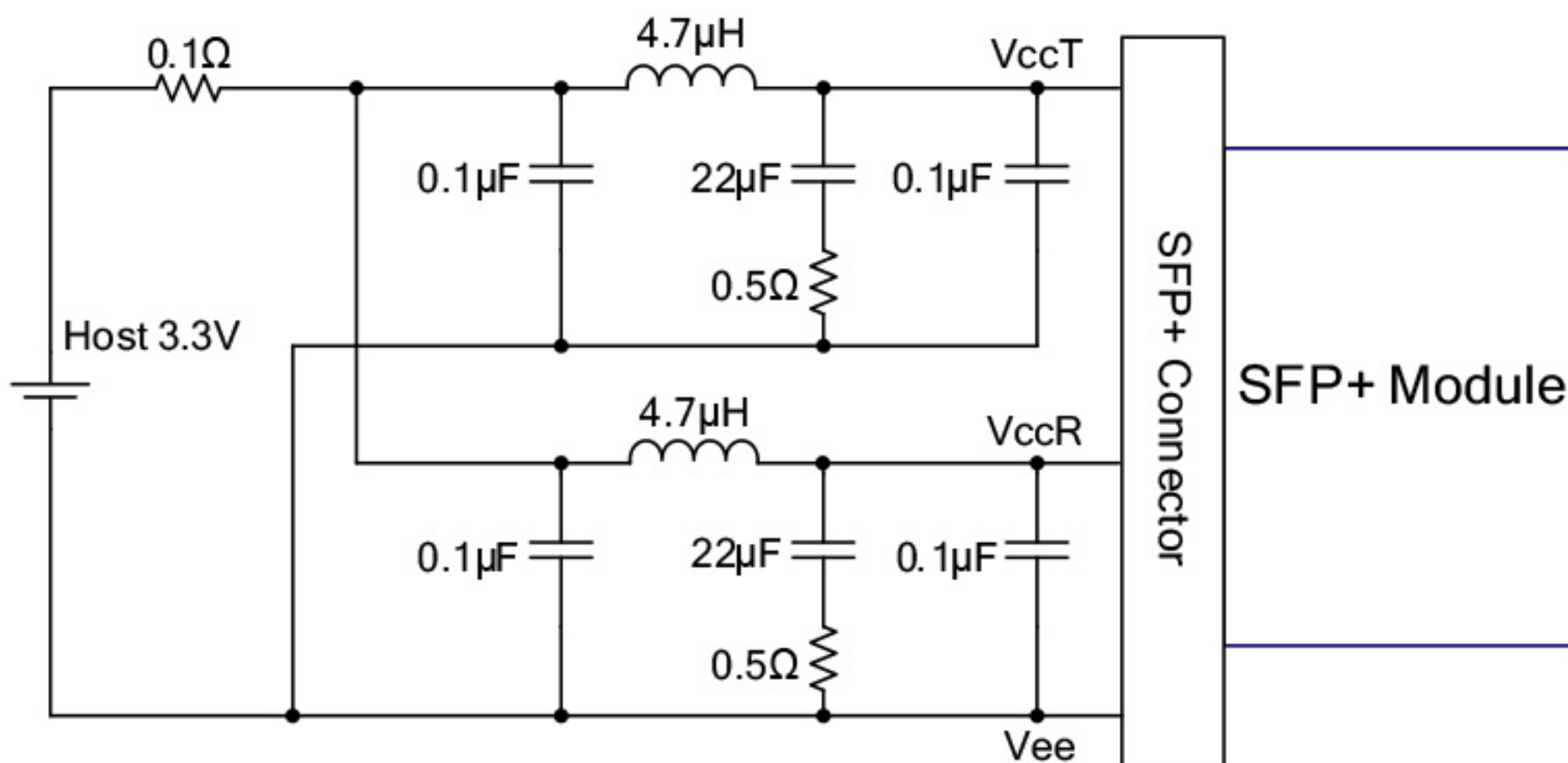

Figure2. Recommended Host Board Power Supply Filter Network

Recommended Application Interface Block Diagram

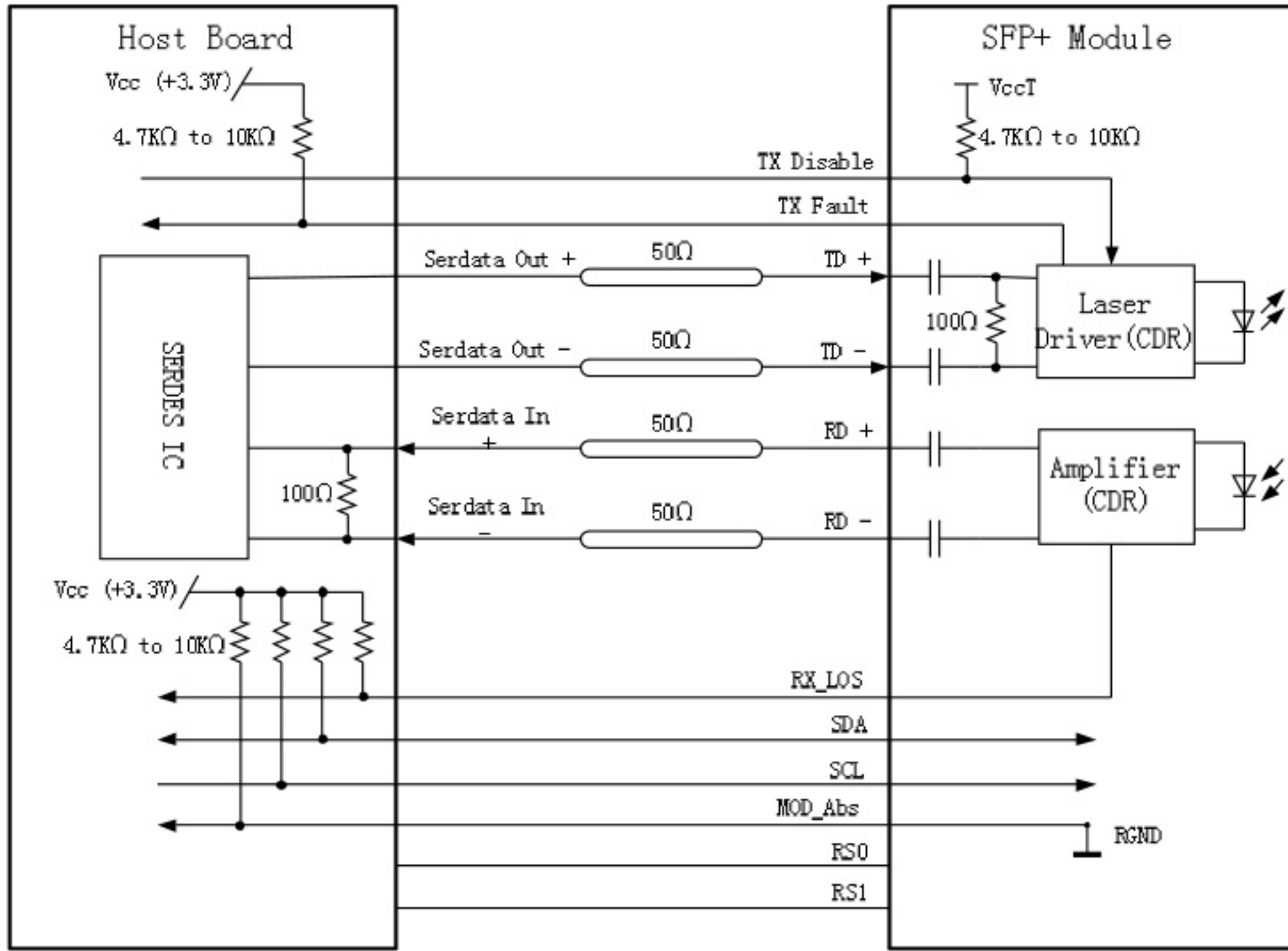

Figure3. Recommended Application Interface Block Diagram

Mechanical Specifications

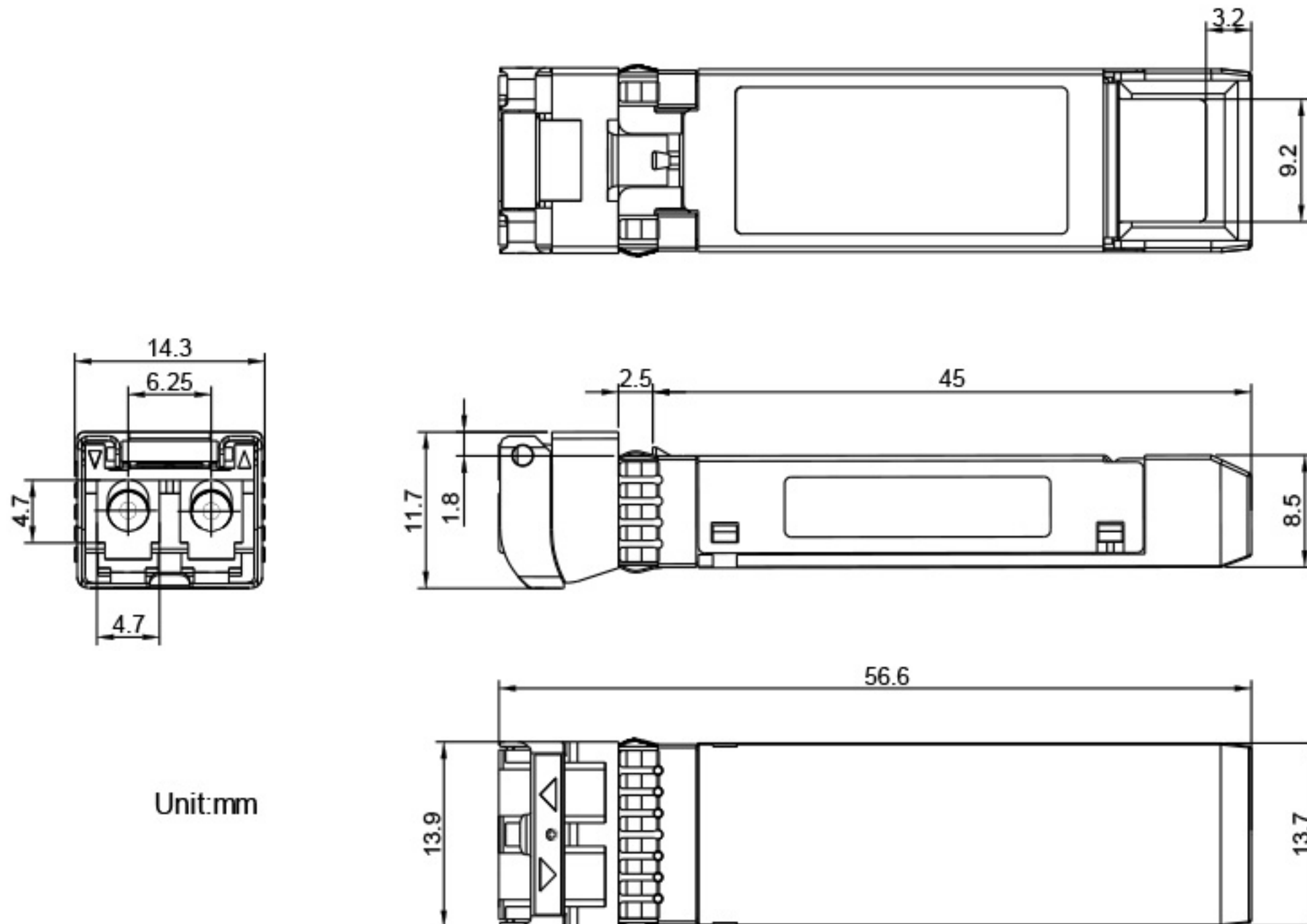

Figure4. Mechanical Specifications

